

CUSTOMER: IMARK		PROJECT: MOTIF	SHEET 1 of 8
		LOCATION: EDMONTON AB	ISSUE:
MATERIAL DESCRIPTION: N/A		 14440-123 Avenue Edmonton, AB T5L 2Y3 Ph. 780-448-8997 Fax 780-448-8896	
Part Name: Regular Mounting Holes - Flat pattern dimensions: N/A X N/A			
QUANTITY: N/A	JOB NUMBER: N/A	www.imarkmetal.com	

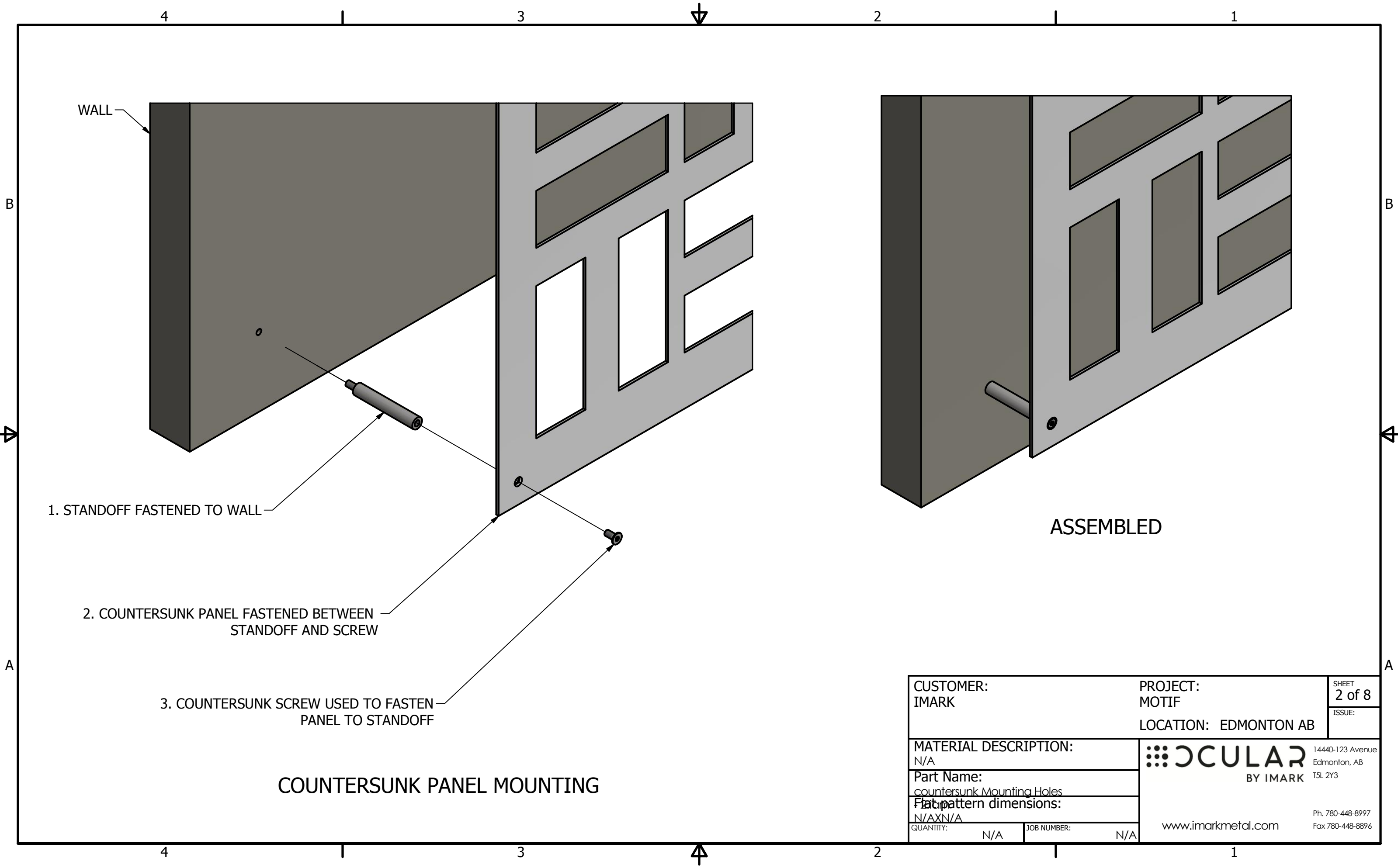

WALL

1. STANDOFF FASTENED TO WALL

2. COUNTERSUNK PANEL FASTENED BETWEEN
STANDOFF AND SCREW

3. COUNTERSUNK SCREW USED TO FASTEN
PANEL TO STANDOFF

COUNTERSUNK PANEL MOUNTING

ASSEMBLED

CUSTOMER: IMARK		PROJECT: MOTIF		SHEET 2 of 8	
		LOCATION: EDMONTON AB		ISSUE:	
MATERIAL DESCRIPTION: N/A			 14440-123 Avenue Edmonton, AB T5L 2Y3 Ph. 780-448-8997 Fax 780-448-8896		
Part Name: countersunk Mounting Holes					
Flat pattern dimensions: N/A X N/A			www.imarkmetal.com		
QUANTITY:	N/A	JOB NUMBER:	N/A		

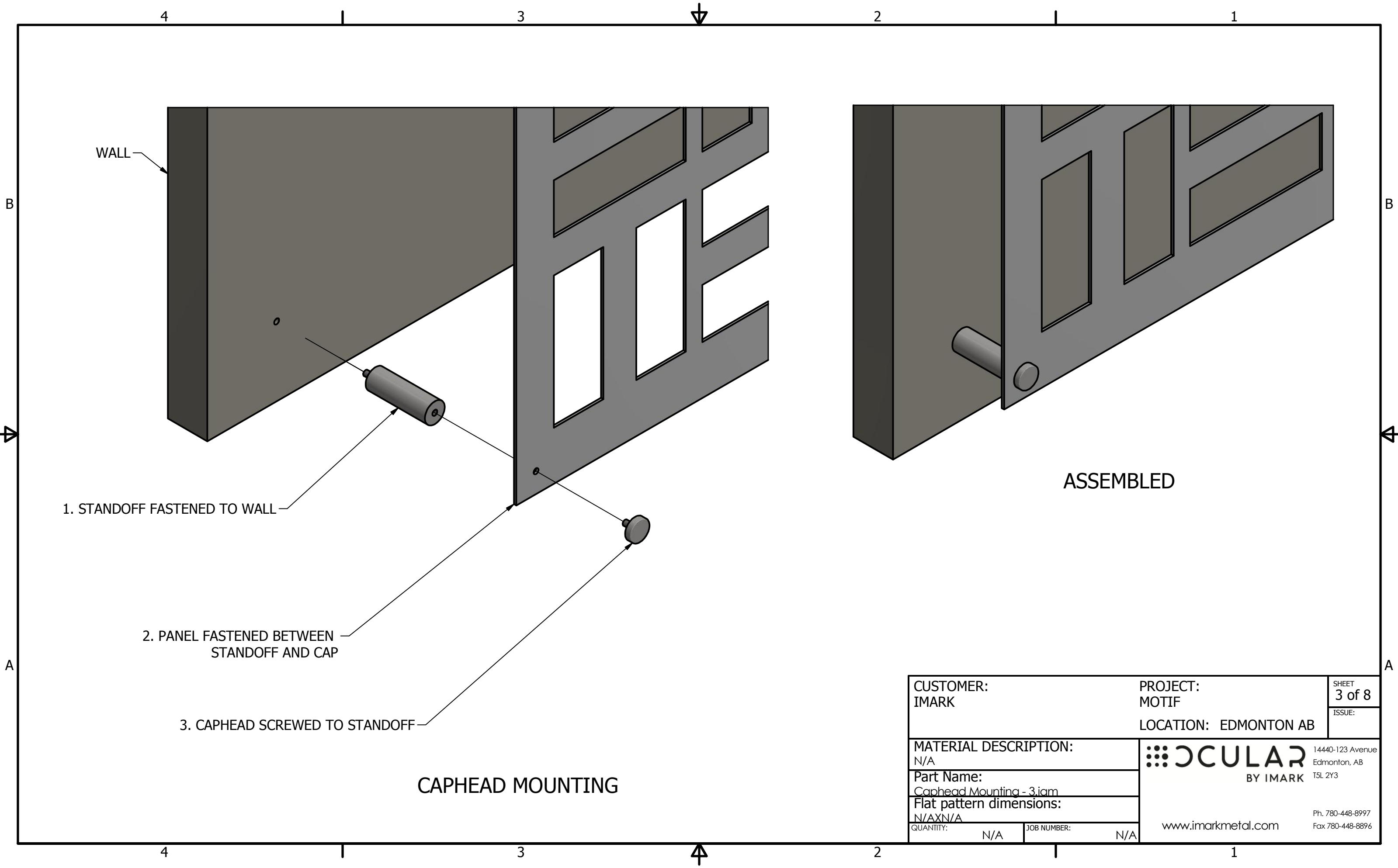

CUSTOMER: IMARK		PROJECT: MOTIF		SHEET 3 of 8	
		LOCATION: EDMONTON AB		ISSUE:	
MATERIAL DESCRIPTION: N/A			 14440-123 Avenue Edmonton, AB T5L 2Y3		
Part Name: Caphead Mounting - 3.iam					
Flat pattern dimensions: N/AXN/A			Ph. 780-448-8997		
QUANTITY:	N/A	JOB NUMBER:	N/A	www.imarkmetal.com	
			Fax 780-448-8896		

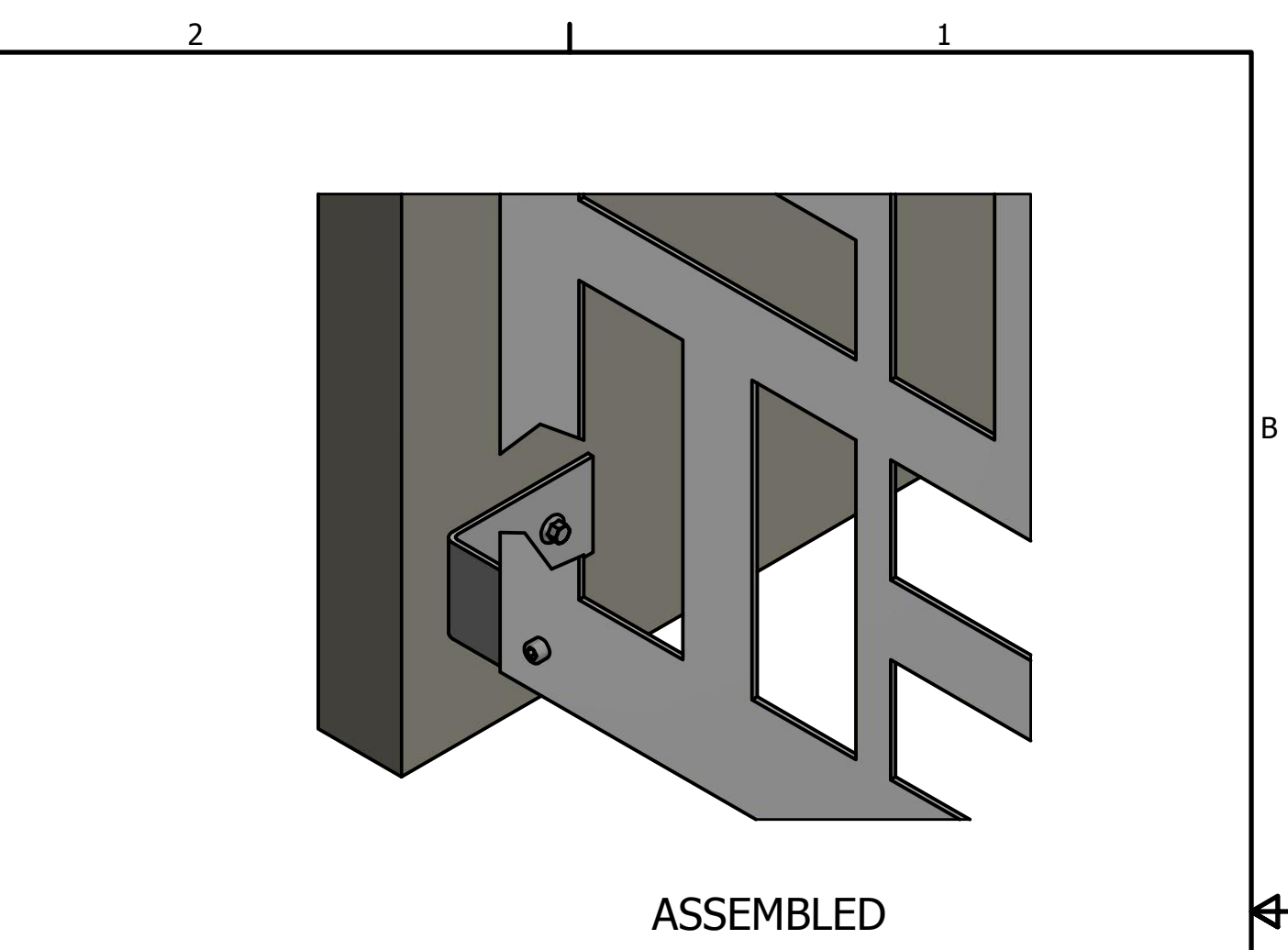
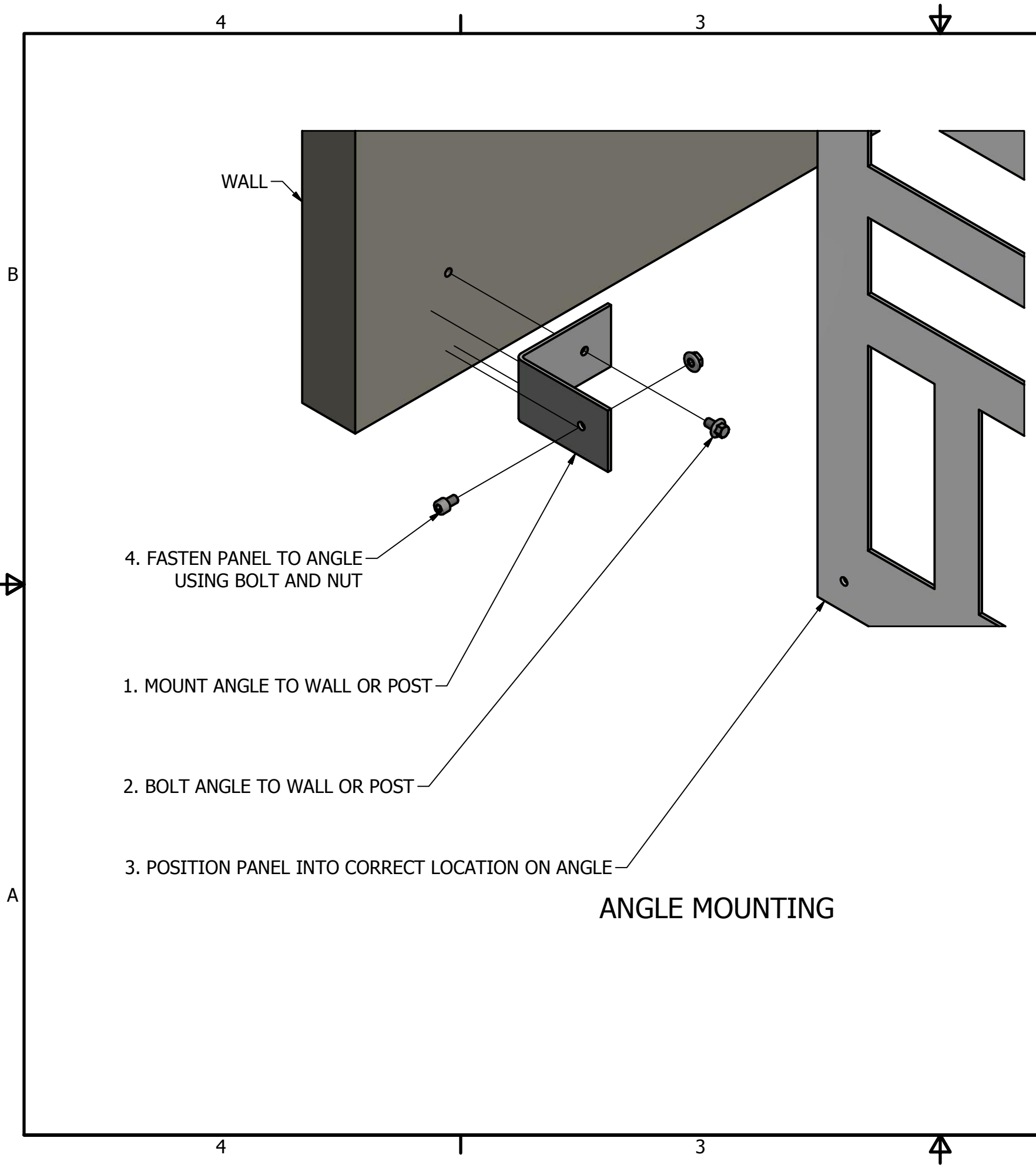

CUSTOMER: IMARK		PROJECT: MOTIF	SHEET 4 of 8
		LOCATION: EDMONTON AB	ISSUE:
MATERIAL DESCRIPTION: N/A		 14440-123 Avenue Edmonton, AB T5L 2Y3	
Part Name: Angle Mounting - 4.iam			
Flat pattern dimensions: N/AXN/A		Ph. 780-448-8997	
QUANTITY: N/A	JOB NUMBER: N/A	www.imarkmetal.com	
		Fax 780-448-8896	

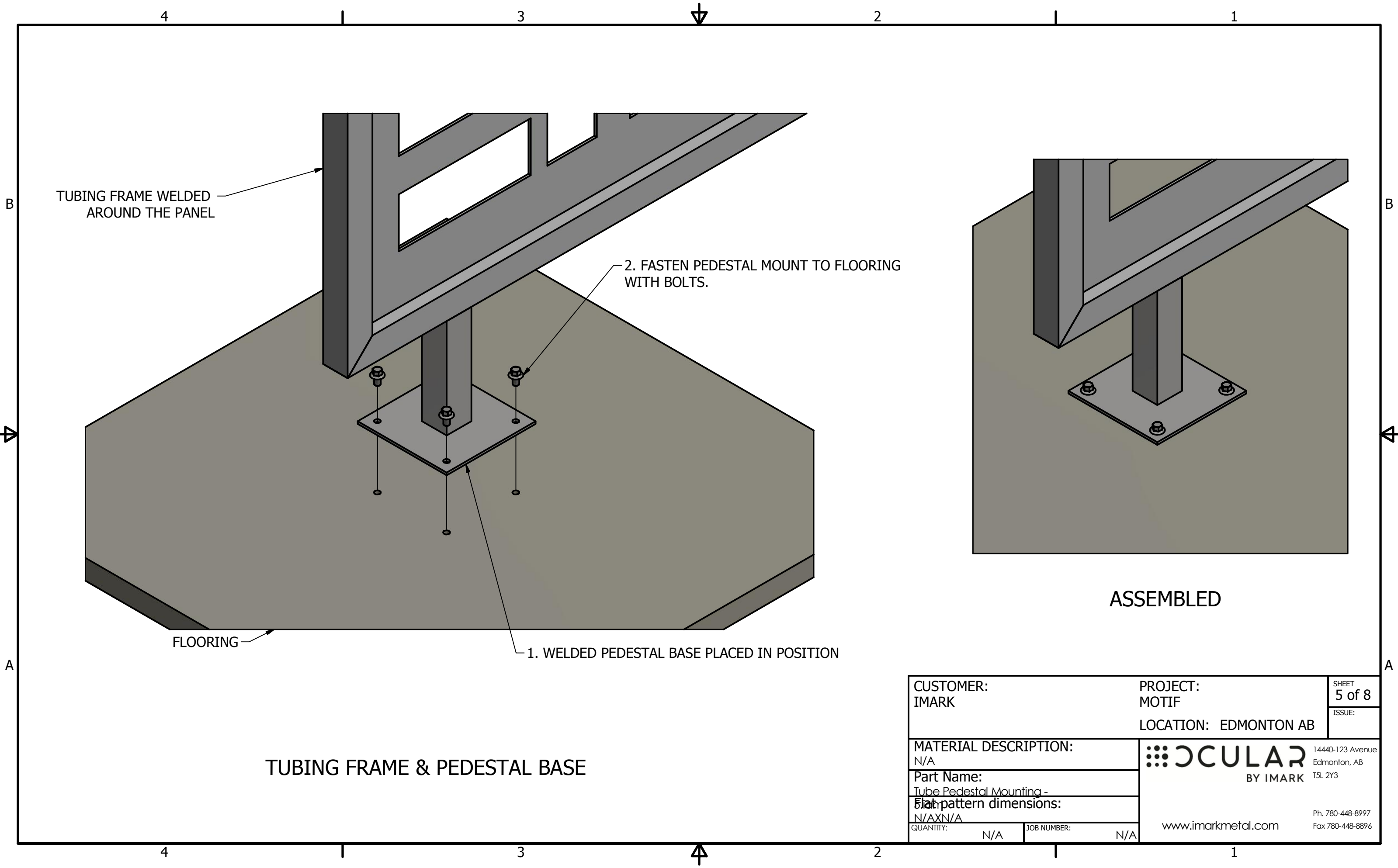

TUBING FRAME WELDED AROUND THE PANEL

2. FASTEN PEDESTAL MOUNT TO FLOORING WITH BOLTS.

FLOORING

1. WELDED PEDESTAL BASE PLACED IN POSITION

ASSEMBLED

TUBING FRAME & PEDESTAL BASE

CUSTOMER: IMARK		PROJECT: MOTIF		SHEET 5 of 8	
		LOCATION: EDMONTON AB		ISSUE:	
MATERIAL DESCRIPTION: N/A			 14440-123 Avenue Edmonton, AB T5L 2Y3 Ph. 780-448-8997 Fax 780-448-8896		
Part Name: Tube Pedestal Mounting - Flat					
Flat pattern dimensions: N/A X N/A			www.imarkmetal.com		
QUANTITY: N/A	JOB NUMBER: N/A				

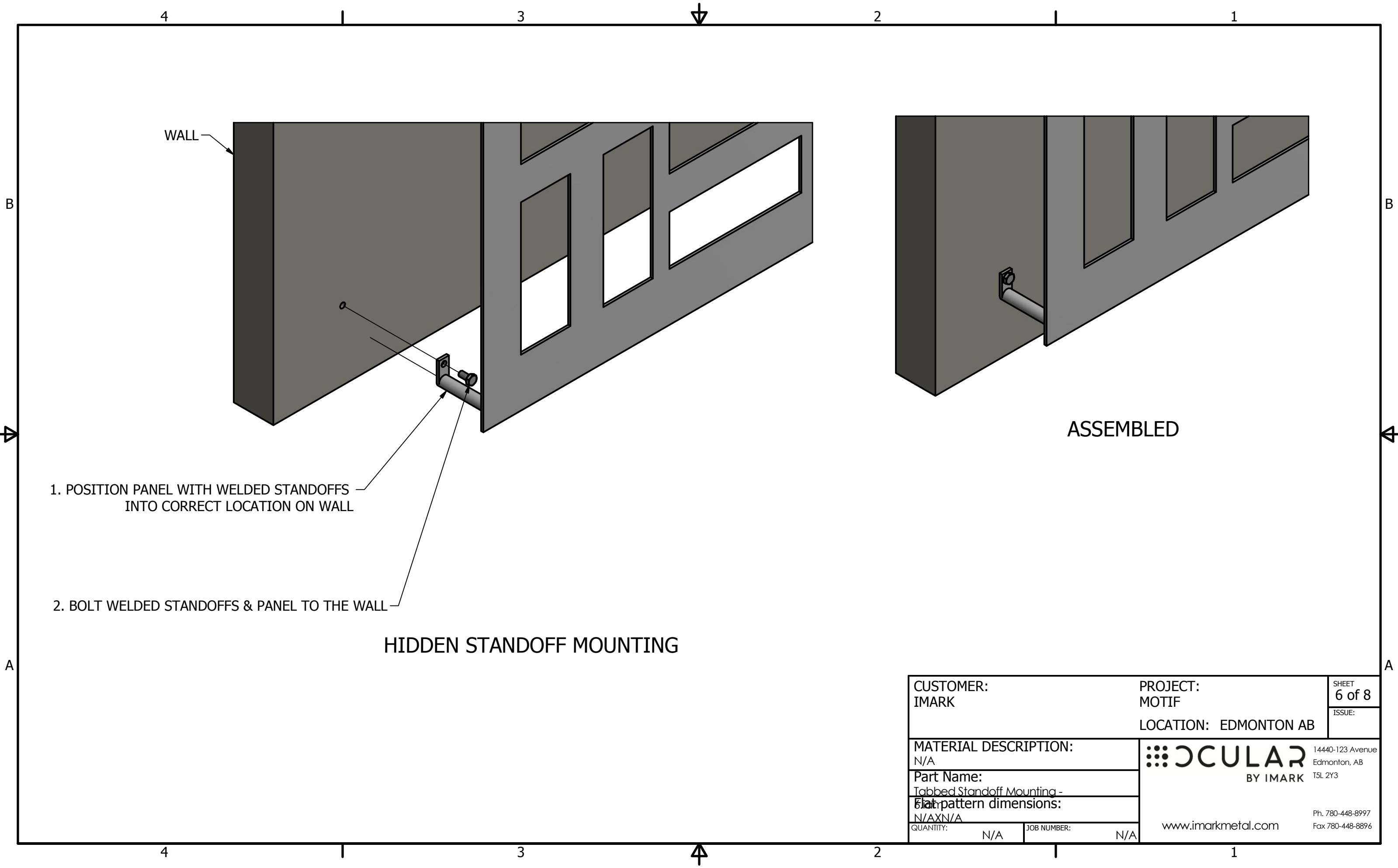

4

3

2

1

B

B

A

A

A

A

WALL

1. POSITION PANEL WITH WELDED STANDOFFS INTO CORRECT LOCATION ON WALL

2. BOLT WELDED STANDOFFS & PANEL TO THE WALL

HIDDEN STANDOFF MOUNTING

ASSEMBLED

CUSTOMER: IMARK		PROJECT: MOTIF		SHEET 6 of 8	
		LOCATION: EDMONTON AB		ISSUE:	
MATERIAL DESCRIPTION: N/A			 14440-123 Avenue Edmonton, AB T5L 2Y3 Ph. 780-448-8997 Fax 780-448-8896		
Part Name: Tabbed Standoff Mounting - Flat					
Flat pattern dimensions: N/A X N/A					
QUANTITY: N/A	JOB NUMBER: N/A		www.imarkmetal.com		

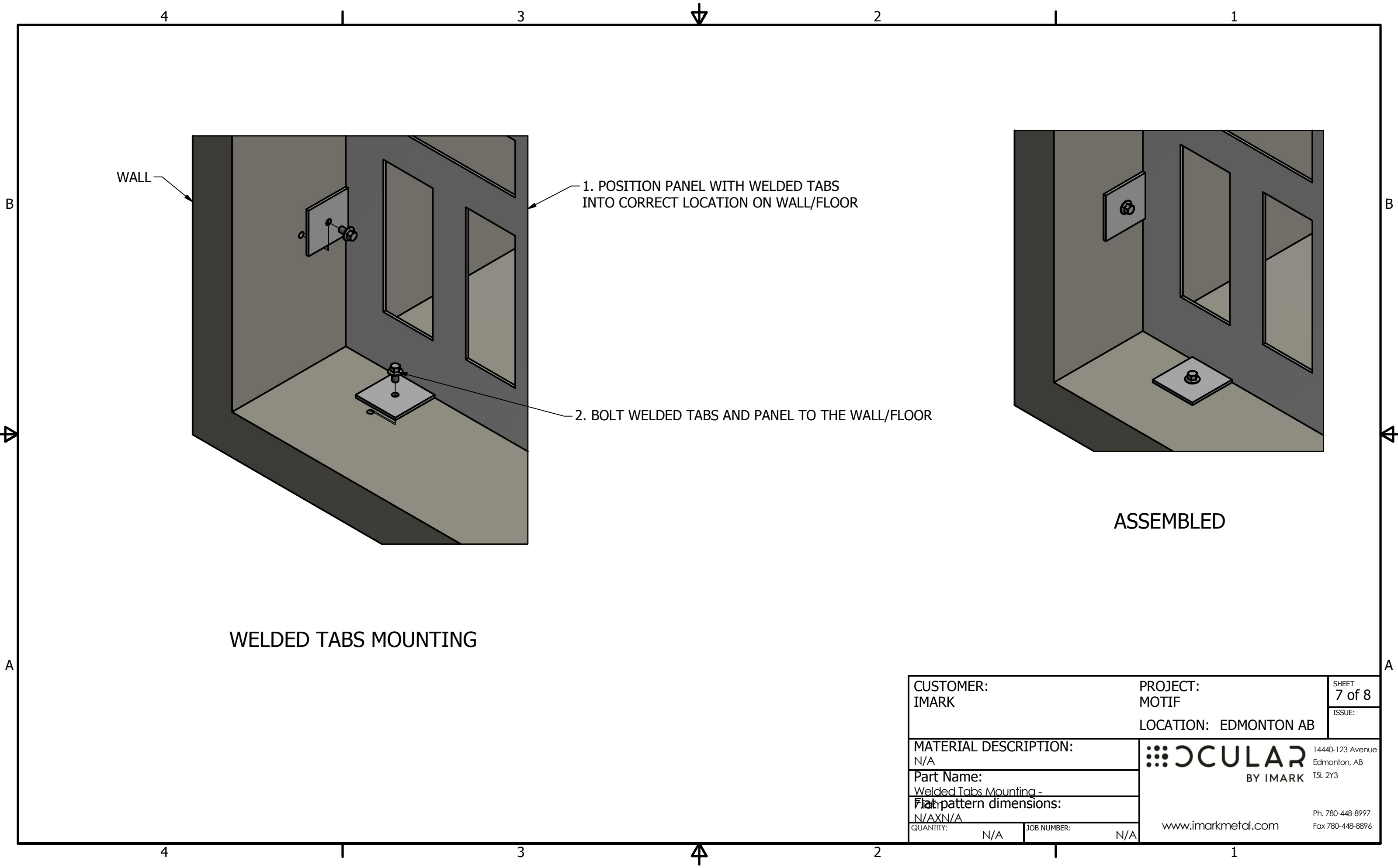

WALL

1. POSITION PANEL WITH WELDED TABS INTO CORRECT LOCATION ON WALL/FLOOR

2. BOLT WELDED TABS AND PANEL TO THE WALL/FLOOR

ASSEMBLED

WELDED TABS MOUNTING

CUSTOMER: IMARK		PROJECT: MOTIF	SHEET 7 of 8
		LOCATION: EDMONTON AB	ISSUE:
MATERIAL DESCRIPTION: N/A		 14440-123 Avenue Edmonton, AB T5L 2Y3 Ph. 780-448-8997 Fax 780-448-8896	
Part Name: Welded Tabs Mounting -			
Flat pattern dimensions: N/A X N/A			
QUANTITY: N/A	JOB NUMBER: N/A	www.imarkmetal.com	

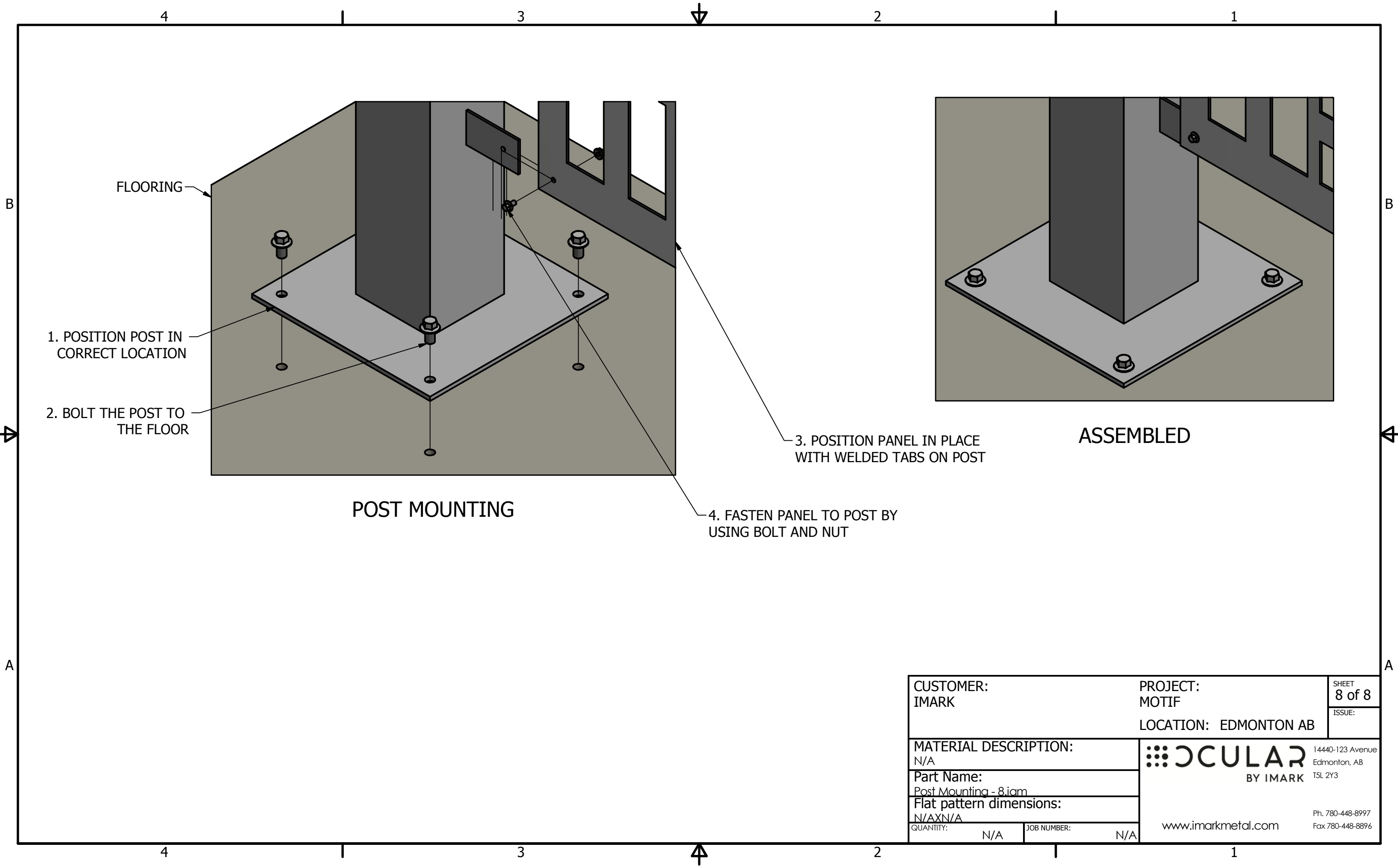

FLOORING

1. POSITION POST IN
CORRECT LOCATION

2. BOLT THE POST TO
THE FLOOR

POST MOUNTING

3. POSITION PANEL IN PLACE
WITH WELDED TABS ON POST

4. FASTEN PANEL TO POST BY
USING BOLT AND NUT

ASSEMBLED

CUSTOMER: IMARK		PROJECT: MOTIF	SHEET 8 of 8
		LOCATION: EDMONTON AB	ISSUE:
MATERIAL DESCRIPTION: N/A		 14440-123 Avenue Edmonton, AB T5L 2Y3 Ph. 780-448-8997 Fax 780-448-8896 www.imarkmetal.com	
Part Name: Post Mounting - 8.iam			
Flat pattern dimensions: N/AXN/A			
QUANTITY: N/A	JOB NUMBER: N/A		